

HDYJ230006 Flat Single-axis Tracking Bracket Sample Installation Manual

Tracking Bracket 1x10-Damper

Authorized by: Wei Jin

Proofread: Yang Zheng

Review: Zhengping Zhu



THE **GARDEN FURNITURE CENTRE** LTD
EST. 1999

Catalog

1、Components list	3
2、Assembly drawing	4
3、The assembly of the driving column	5
4、The assembly of the ordinary column	6
5、The assembly of the reducer	7
6、The assembly of the main axis	8
7、The assembly of the purlin	10
8、The assembly of the modules	11
9、The assembly of the axis cover	12
10、The assembly of the equipotential conductor	13
11、The assembly of the controller	14
12、The assembly of the damper	15

No.	Descriptions	Specification	Qty	Unit	Remarks
1	Driving column H type steel	L=2590mm	1	pc	H200x100x3.3x4.2
2	ordinary column C type steel	L=2680mm	2	pc	C160x65x14x3
3	Welding part on the bearing seat	welding parts	2	pc	steel board: -4/-3
4	Welding part under the bearing seat	welding parts	2	pc	steel board: -4/-3/-4
5	Ball bearing	140	4	pc	Matching holding bearings and 140 main axis
6	Main axis limiter	-3.5x300x36	4	pc	ZAM: -3.5
7	Main axis	□140x140x2.5, L=4000	2	pc	NO..A
8	Main axis	□140x140x2.5, L=2100	4	pc	NO.B
10	Main axis hoop	-5x300x330	4	pc	steel board: -5
11	Purlin holding boards assy	welding parts	12	pc	welding parts, average HDG 65µm
12	Purlin hoop	-3.5x426.5x22	12	pc	steel board: -3.5
13	Purlin hoop pad	-5x20x20	24	pc	purlin holding boards assy+purlin hoop
14	Purlin	L=1000mm	12	pc	HD/L83x40x30x1.8
15	Reducer seat assy	welding parts	2	pc	steel board: -12/-8/-6
16	Damper arm	welding parts	2	pc	steel board: -5/-4/-2
17	Damper arm hoop	-4x442.5x26	4	pc	steel board: -4
18	Reinforcing board for damper arm hoop	-4x84x27	4	pc	steel board: -4
19	Lower bracket assy for damper	welding parts	2	pc	steel board: -6/-5/-6
20	Axis sleeve	L=25	24	pc	Φ16x2, 20#, purlin+purlin hoop
21	Axis sleeve	L=7	4	pc	Φ30x7, plastic parts, for the use of damper
22	Axis sleeve	L=5	4	pc	Φ30x7, plastic parts, for the use of damper
23	damper+damper up+down bracket arry	Φ14x65x4 B type Pinshaft with holes	4	pc	/
24	Welding part on the bearing seat+Welding part under the bearing seat	Φ12x80x4 B type Pinshaft with holes	4	pc	/
25	Controller hoop	Stainless steel, M8-U type, with 140 square tube	2	pc	with 1 large flat pad,1 spring pad and 1 bolt
26	Antenna mounting plate	-2x83x32	1	pc	install on the controller
27	Square pad	-4x100x50	8	pc	use for main axis+reducer
28	Round pad	-4x46x46	4	pc	use for reducer+bracket
29	Cotter pins	Φ3.2X30	16	pc	/
30	Main axis end caps	-0.5x144x144,with 140 square tube	2	pc	Galvanized sheet
31	damper	AST-30-430Q	2	pc	/
32	Reducer	FD07V055D140R1D01	1	pc	/
33	bolts for fixing the modules	A2-70, M8x25 Allen bolts	40	pc	wit two flat pads,1 spring pad and 1 nut
34	purlin holding plate assy+purlin hoop	8.8 class HDG, M8x35 Allen bolts	24	pc	wit two flat pads,1 spring pad and 1 nut
35	Main axis limiter+Main axis limiter	8.8 class HDG, M10x30 Allen bolts	4	pc	wit two flat pads,1 spring pad and 1 nut
36	Purlin holding plate assy+purlin	8.8 class HDG, M10x60 Allen bolts	24	pc	wit two flat pads,1 spring pad and 1 nut
37	ordinary column+Welding part under the bearing seat	8.8 class HDG, M12x45 Allen bolts	8	pc	wit two flat pads,1 spring pad and 1 nut
38	Driving column+reducer seat	8.8 class HDG, M12x45 Allen bolts	12	pc	wit two flat pads,1 spring pad and 1 nut
39	damper arm+hoop assy	8.8 class HDG, M12x45 Allen bolts	8	pc	wit two flat pads,1 spring pad and 1 nut
40	ordinary column+damper down bracket	8.8 class HDG, M12x45 Allen bolts	8	pc	wit two flat pads,1 spring pad and 1 nut
41	main hoop+main axis hoop	8.8 class HDG, M12x45 Allen bolts	24	pc	wit two flat pads,1 spring pad and 1 nut
42	main axis hoop+main axis	8.8 class HDG, M14x180 Allen bolts	4	pc	wit two flat pads,1 spring pad and 1 nut
43	main axis+reducer	8.8 class HDG, M16x35 Allen bolts	16	pc	with 1 flat pad and 1 spring pad
44	reducer+reducer seat	8.8 class HDG, M20x90 Allen bolts	4	pc	with 1 large flat pad and 1 spring pad, 2 nuts

2-2-Assembly drawing

Dimensions in millimeters

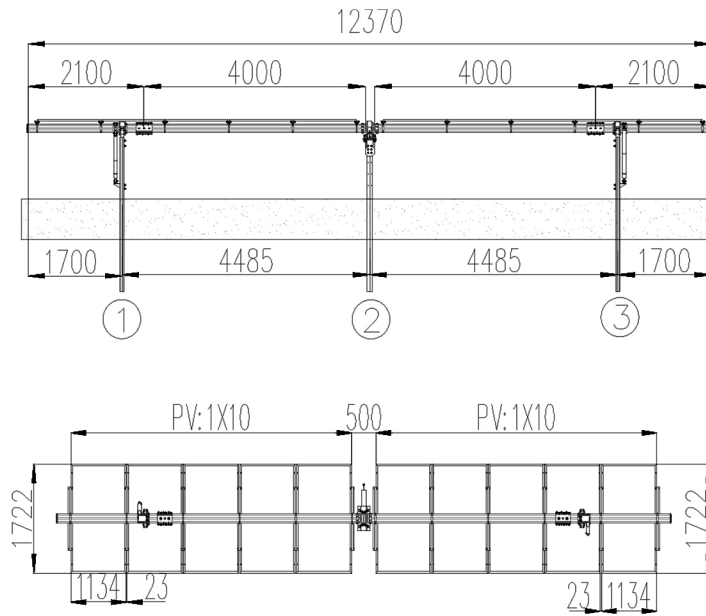

- Re:
1. This is array 1x10 single horizontal axis;
 2. Module 1722x1134x30, power is 400wp;
 3. Tracking angle $\pm 55^\circ$;
 4. Bracket $\pm 55^\circ$ 时, the lowest distance to the ground is 600mm;
 5. There are 3 columns, ② is driving column;
 6. Column ① and ③ are ordinary column;
 7. On the ordinary column ① and ③ install the damper;
 8. There are total 4 axes;
 9. Steel pile, buried into earth 1.6M

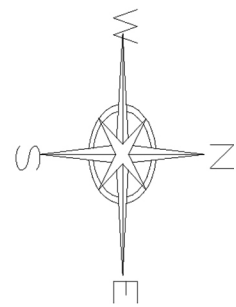
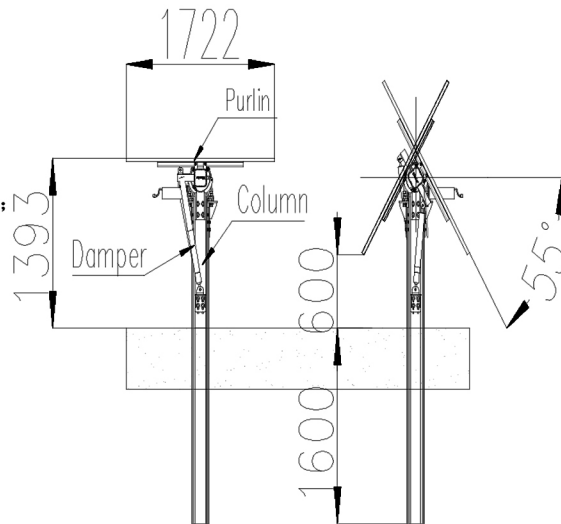

3-3-The assembly of driving column

1 Materials

Driving column 1pcs

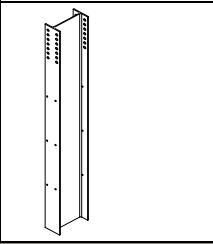

2 The assembly of driving column

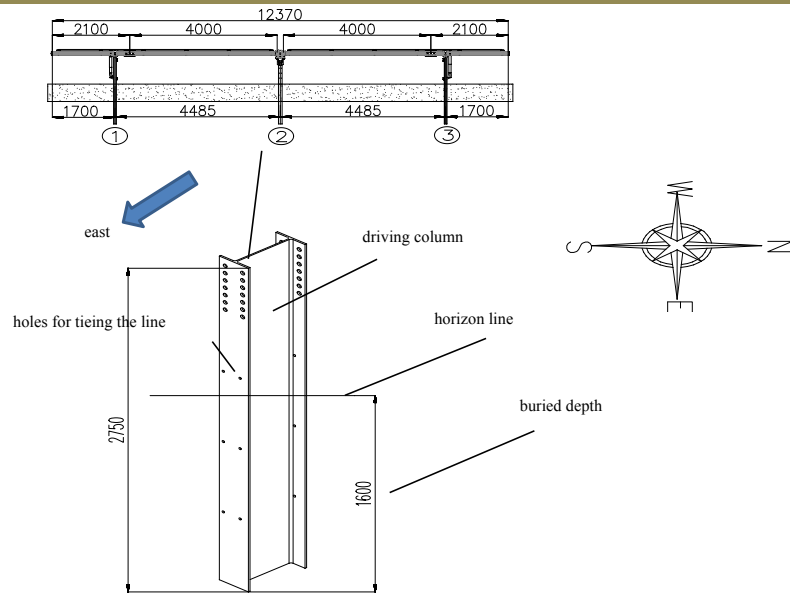

3 Technical requirement

1. ② is driving column, 1pc;
2. When the drive column is installed, it is centered and symmetrical as a whole, keeping it vertical;
3. Column horizontal deflection angle limit: $\pm 1^\circ$; Column verticality deviation: $\pm 1^\circ$

4-The Assembly of ordinary column

1 Materials

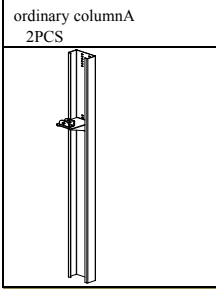

2 The assembly of ordinary column A

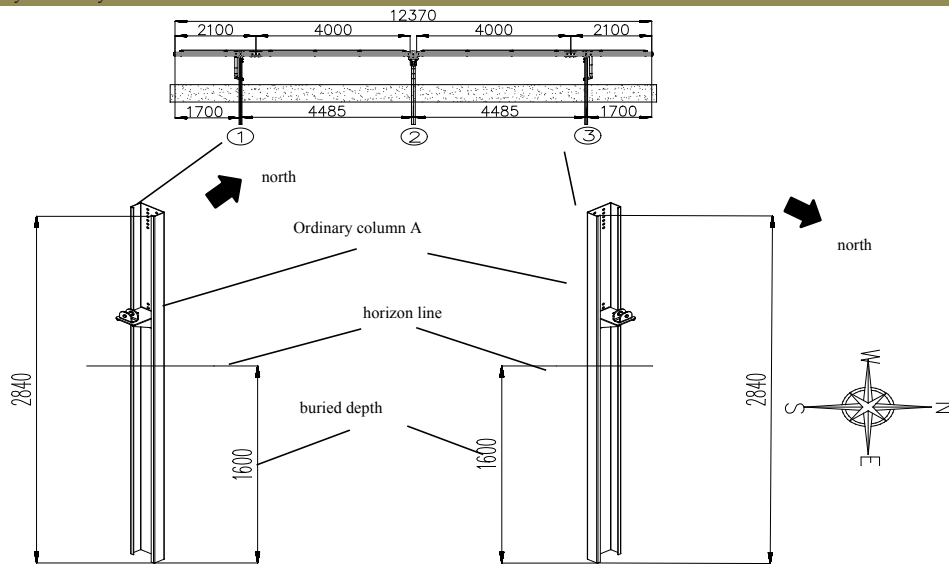

3 Technical requirement

1. ①③ are ordinary column A, total 2pcs
2. Ordinary column A is installed overall centered and symmetrical ;
3. Adjust the height of ordinary column A based on the position of the driving column to ensure that all axes are installed horizontally;
4. Ordinary column A stays vertical, and at the same height;
5. The height construction deviation of ordinary column A in the north-south direction is guaranteed to be within $\pm 20\text{mm}$; The position deviation in the east-west direction is guaranteed to be within $\pm 20\text{mm}$;
6. The height construction deviation of ordinary column A in the north-south direction is guaranteed to be within $\pm 20\text{mm}$; The position deviation in the east-west direction is guaranteed to be within $\pm 20\text{mm}$

5-The assembly of the reducer

1 Materials					
reducer base 2pcs	reducer 1pcs	M12×45 12pcs	M12large flat pad 24pcs	M12spring washer 12pcs	M12nut 12pcs
M20x90outer hexgon bolt 4pcs	round pad of reducer 4pcs	M20 spring pad 4pcs	M20flat pad 4pcs	M20nut 8pcs	

2 The assembly of reducer

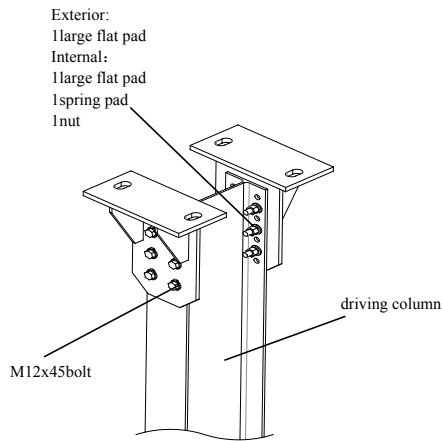

M12X45 bolts: 12pcs
M12 large flat pad: 24pcs
M12 spring pad: 12pcs
M12 nut: 12pcs
Tightening torque: 85N.m

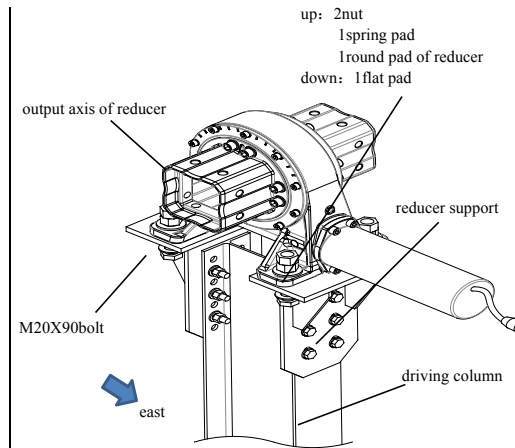









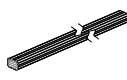

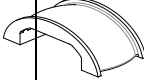







M20X90 bolts: 4pcs
M20 flat pads: 4pcs
round pad of reducer: 4pcs
M20 spring pad: 4pcs
M20 nut: 8pcs
Tightening torque: 425N.m

3 Technical requirement

1. On the Column②install the support of reducer, install the reducer on the support, make sure it is stable and horizontal with the axis of output axis Parallel to north-south and symmetrical to drive column; Parallel to north-south and symmetrical to drive column;
2. The mounting bolts of the reducer (M20) the direction will be showed like Pic.;
3. The motor is mounted securely with the tail facing east (as shown in the picture).

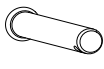
6-bearing seat+main axis installation

1.material						
main axis A 4m	main axis B 2.1m	square pad	main axis hoop	ball bearing	Welding parts under the bearing	Welding parts on the bearing
2pcs	2pcs	8pcs	4pcs	4pcs	2pcs	2pcs
						
M14X160outer hexagon bolt	M12X45outer hexagon bolt	M16x35outer hexagon bolt	M14 nut	M12 nut	M16 spring pads	M14 spring pads
4pcs	32pcs	16pcs	4pcs	32pcs	16pcs	4pcs
						
M12 spring pads	M14large flat pads	M12large flat pads	M12 flat pads	pin12x80x4	Cotter pins4.0x30	main axis limiter
32pcs	8pcs	16pcs	48pcs	4pcs	4pcs	4pcs
						

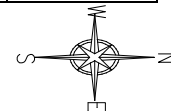

2 The assembly of bearing seat

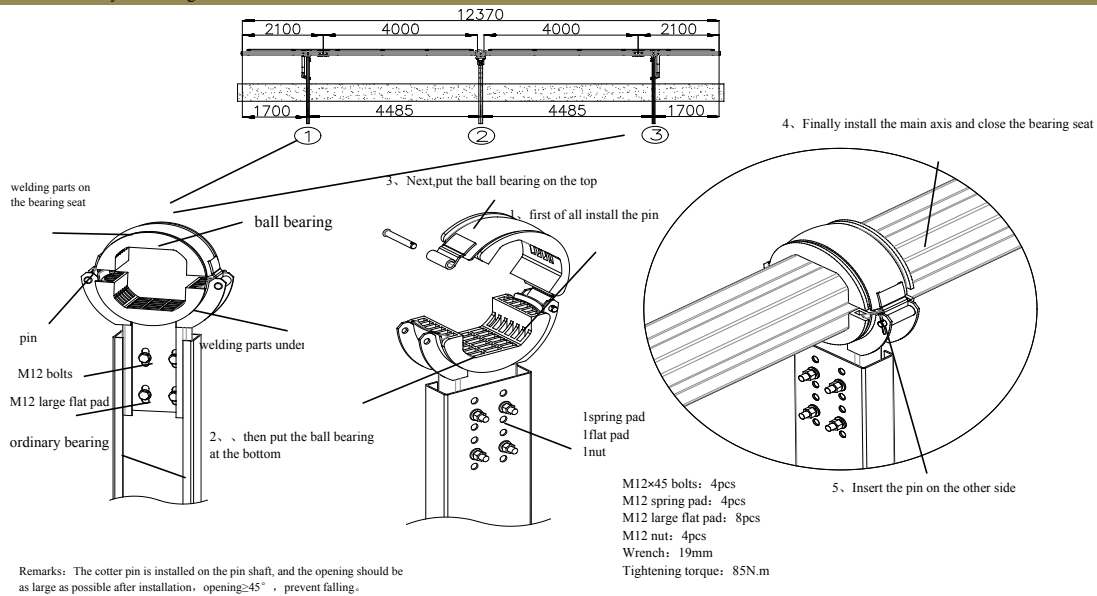

6-bearing seat+main axis installation

3 The assembly of axis limiter

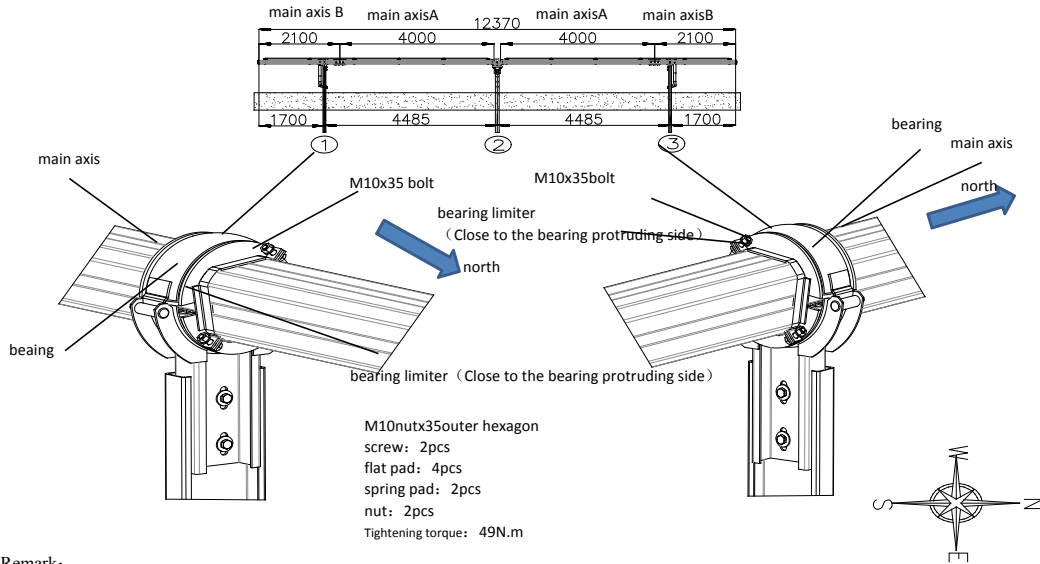

Remark:

1.The bearing limiter at the upper end of the common and damping columns is fixed with M10 nuts, one of which is borrowed and fixed by the equipotential wire.

4The assembly of the two sides of reducer and main axis

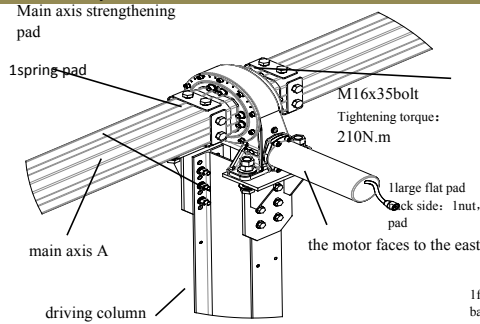



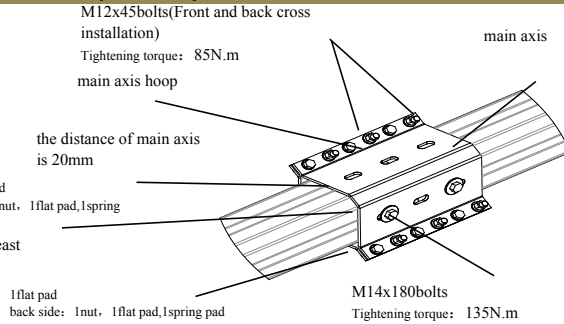







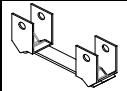

5The assembly of axis hoop and axis



6 technical requirements

1. The overall installation should be firm and beautiful;
2. Pay attention to the installation direction of the bearing, the side of the extrude is facing the direction of the driving column
3. Bearing limiter: firmly installed, close to the side of the bearing extrude,
4. Keep the overall axis in horizontal
5. After the axis installed with hoops, the spacing is 20mm;

7-The assembly of purlins

1 Materials						
purlin 12pcs	the sub-assembly of 12pcs	purlin hoop 12pcs	pad of purlin hoop 24pcs	M8X35 outer hexagon bolt 24pcs	M10X60 outer hexagon bolt 24pcs	
						
M8 flat pad 48pcs	M10 flat pads 48pcs	10 spring pads 24pcs	8 spring pads 24pcs	M8 nut 24pcs	M10 nut 24pcs	16x25 axis sleeve 24pcs
						

2 The assembly of purlin

M8X35 outer hexagon bolt: 2PCS The long waist hole here is convenient for adjustment

M8 flat pad: 4PCS

M8 flat spring pad: 2PCS

M8 nut: 2PCS

Tightening torque: 25N.m

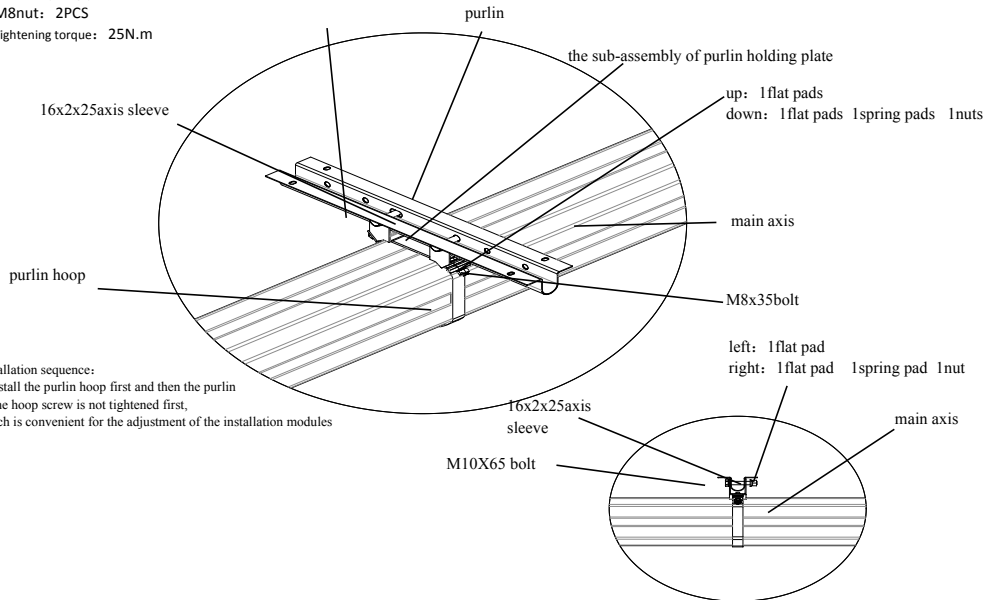





Installation sequence:

1. Install the purlin hoop first and then the purlin
2. The hoop screw is not tightened first, which is convenient for the adjustment of the installation modules

3 Technical requirement

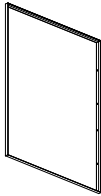
1. The overall installation should be firm and beautiful;
2. After the overall installation, the spacing is even and the height is equal.

8-The assembly of modules

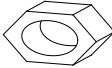
1 Materials				
Module 400w	M6X25outer hexagon bolt	M8 flat pad (SUS304)	M8 flat pad (SUS304)	M8 bolt A2-70
10pcs	40pcs	80pcs	40pcs	40pcs
				

2 The assembly of modules

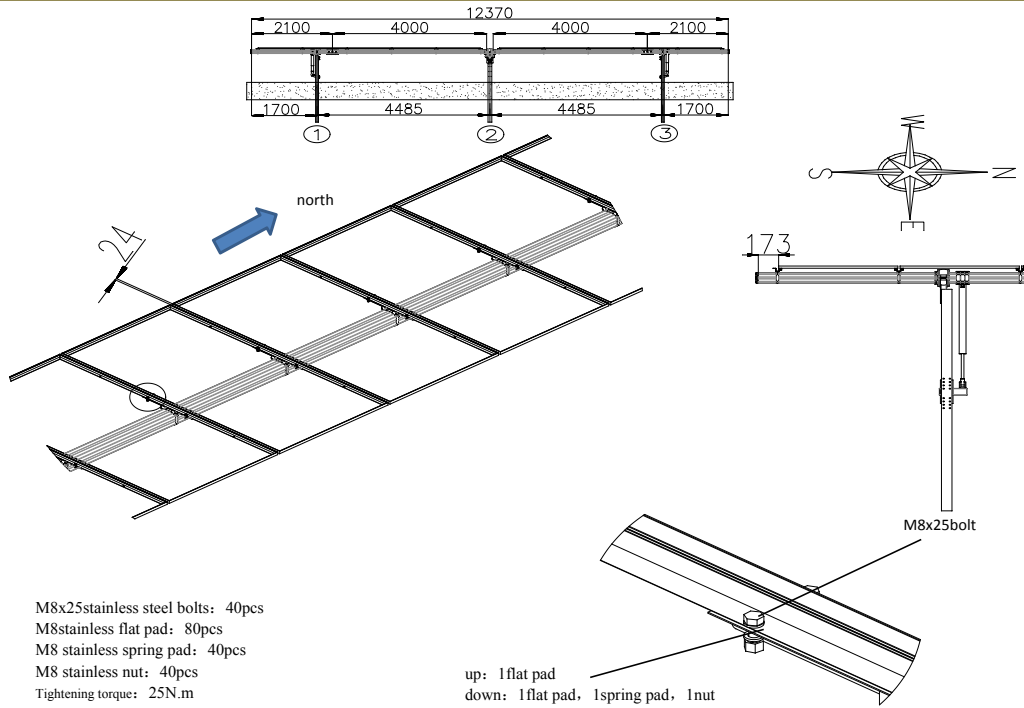

M8x25stainless steel bolts: 40pcs
M8stainless flat pad: 80pcs
M8 stainless spring pad: 40pcs
M8 stainless nut: 40pcs
Tightening torque: 25N.m

3 Technical requirement

1. The overall installation of the components should be firm and beautiful;
2. After the overall assembly is installed, the spacing is uniform, the two sides are symmetrical, and the height is equal;
3. Recommended clearance distance between components is 23mm.
4. The distance between the first module and the main axis is shown in the figure 173mm.

9-The installation of the main axis cover

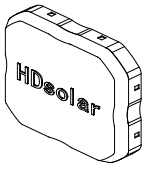
1 Material	
main axis cover	
2pcs	
	

2 Installation of the axis cover

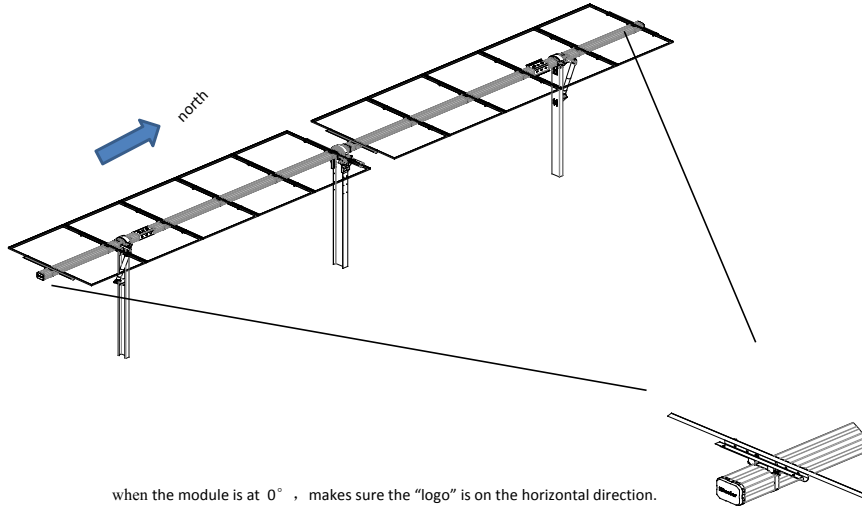

3 Technical requirement

1. One end cover is installed at each end of the single-row flat single-axis, and when the component is placed flat, the characters on the end cover are all upward and horizontal;
2. The end cover is installed in place: the inner concave surface coincides with the end surface of the main axis, and the outer convex surface is symmetrical and perpendicular to the main axis.

10-The installation of equipotential conductor

1 Materials

equipotential conductor
2pcs

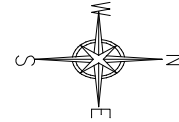



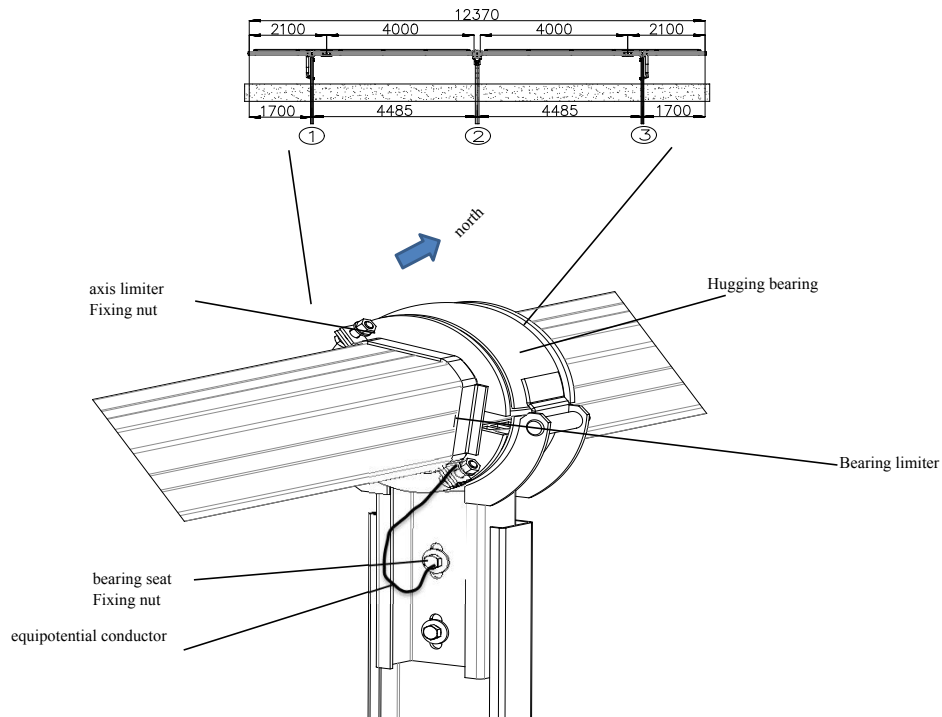



2 Installation of the axis cover

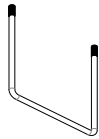
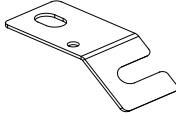

3 Technical requirement

1. One potential wire should be installed between the housing and bearing limit parts at the upper end of the column (1) and the column (3).;
2. Before installing the equipotential conductor, put the photovoltaic module flat first;
3. After the two ends of the equipotential conductor are fixed, the bent part should face downward. ;
4. After the installation is completed, the equipotential conductor still has some bending allowance when the main axis is turned over at the maximum angle in both positive and negative directions. ;
5. Both ends of the equipotential wire (cold-pressed end) are firmly installed and in good contact.
6. When the modules are installed, ensure that the edges of all modules are on the same straight line to ensure the aesthetics of the installation.

11-The installation of the controller

1 Materials					
main controller	shape bolt for the control	Antenna fixing plate	M8large flat pad (SUS304)	M8 spring pad (SUS304)	M8 nut
1pcs	2pcs	1pcs	4pcs	4pcs	A2-70
					



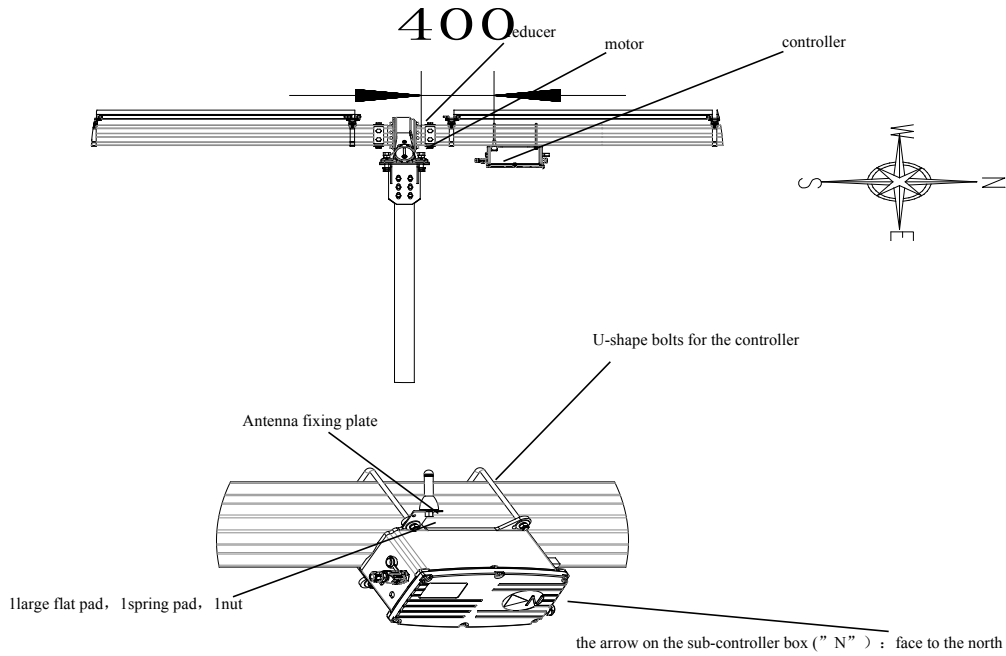







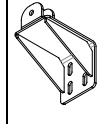

2 The installation of the main controller



3 Technical requirement

1. The overall installation is firm and beautiful, without stains, damage, etc.
2. The controller is 400mm away to the end of the reducer connecting axis

12-The installation of damper

1 Materials						
damper 2pcs	damper arm 2pcs	damper hoop 4pcs	damper lower bracket 2pcs	damper axis sleeve A 4pcs	pin 14x65x4 4pcs	M12x45 outer hexagon head bolt 16pcs
						
M12 spring pad 16pcs	M12 large flat pad 16pcs	pin 14x65 4pcs	M12 flat pad 16pcs	damper axis sleeve B 4pcs	pin 3.2x30 4pcs	nut 16pcs
						

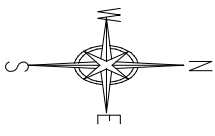

2 Installation diagram of the damper

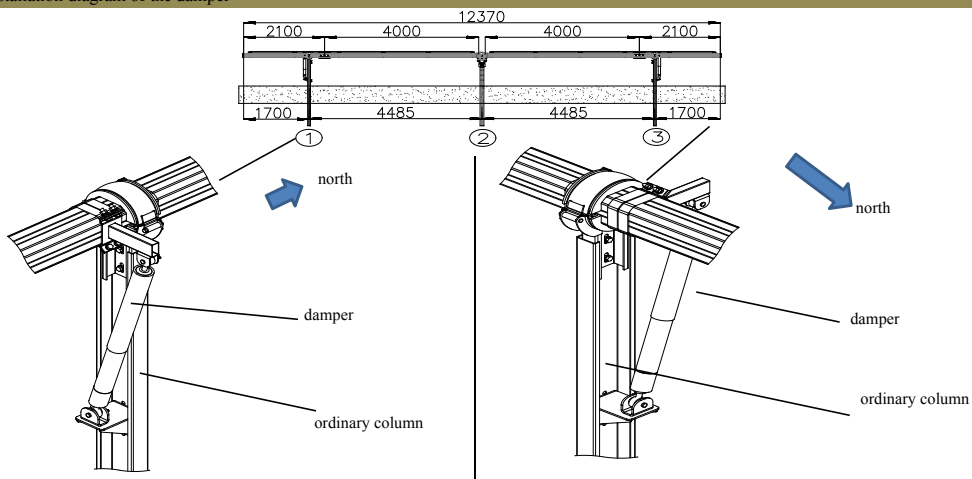

3 Damper upper bracket installation

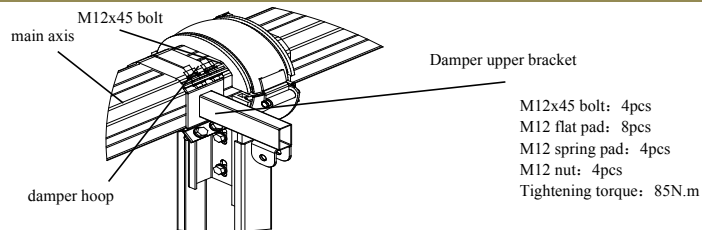

4 Damper lower bracket installation

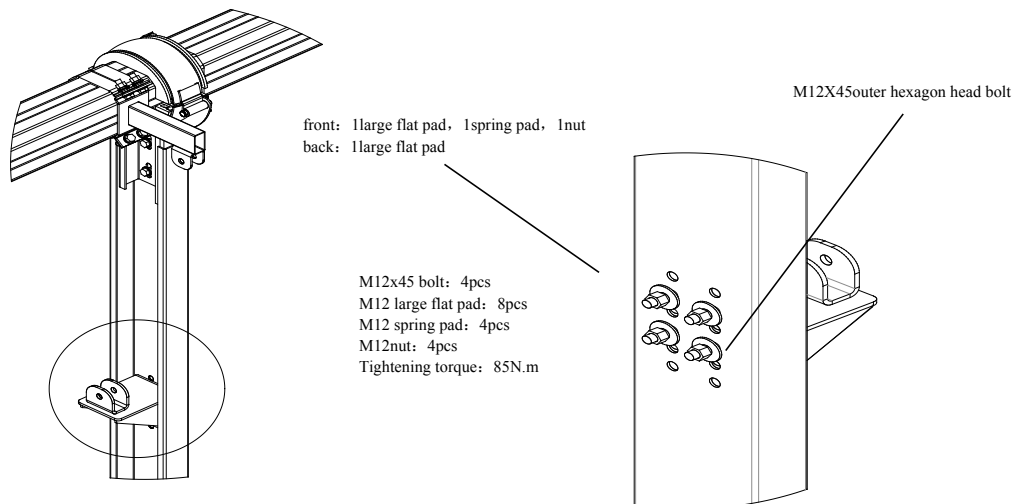

Remarks: The installation holes are the second row of holes counted from top to bottom and the third row of holes counted from bottom to top

5 The installation of damper and pin

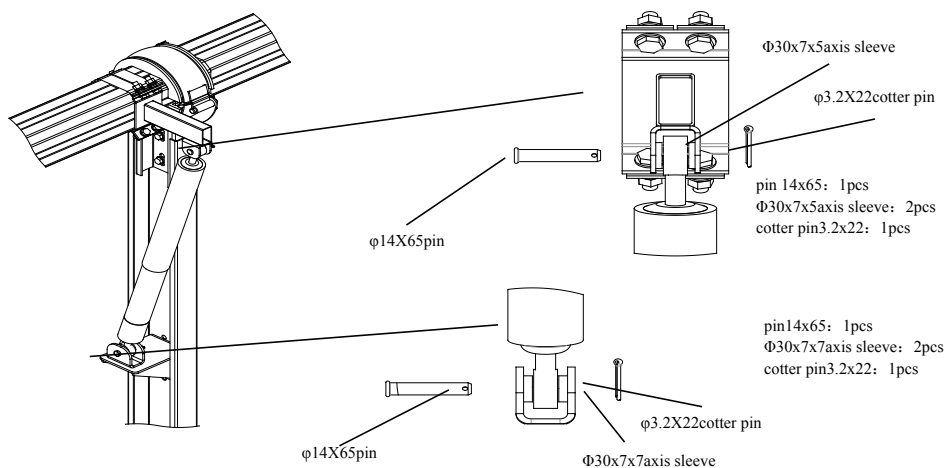

6 technical requirements

1. The overall installation is firm and beautiful, without interfering with the active space of the axis and bearings;
2. Ensure that the axis in the telescopic direction of the damper is perpendicular to the axis of the main shaft;
3. After the damper is installed, it needs to expand and contract naturally without distortion;
4. After the cotter pin is installed, the opening should be as large as possible, opening $\geq 45^\circ$, prevent falling.

13-cable connection

1 cable			
cable	starting point	end point	remarks
motor cable	motor cable	controller	Motor comes with
antenna cable	antenna cable	controller	Controller comes with
power cable (+)	Splitter (+)	controller	red cable
power cable (-)	Splitter (-)	controller	black cable

2 线缆安装

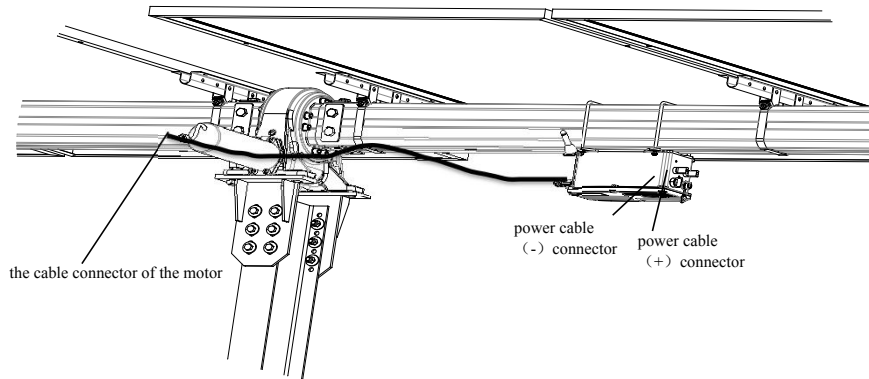

THE GARDEN FURNITURE CENTRE LTD

EST. 1999